

## N38300 Series Wide Range High Power Programmable DC Power Supply

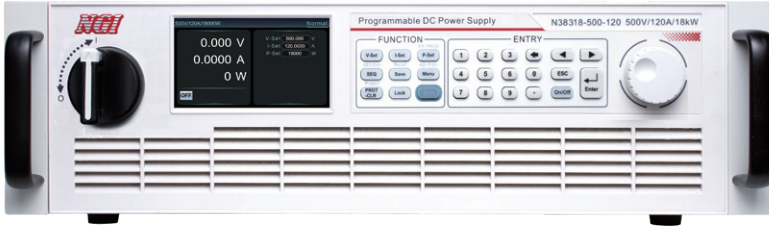

### Product Introduction

N38300 series is a wide range, high power density, programmable high power DC power supply. N38300 standalone 19-inch 3U chassis is up to 18kW. Power efficiency is as high as 93%. Power range is up to 180kW. Current range is up to 5100A and voltage range is up to 2250V, master-slave parallel expansion power up to 1.8MW. N38300 series DC power supply has comprehensive functions and supports multiple control methods, making it an ideal choice for laboratory applications and automated test systems.

### Application Fields

- ▶ New energy fields, such as Li-on battery, photovoltaic, hydrogen fuel, energy storage BMS, etc.
- ▶ Testing and powering of high power electronic component
- ▶ Laboratory, production line ATE automatic test system
- ▶ Power electronics fields, such as high power DC-DC converter, DC-AC inverter, etc.
- ▶ Testing and powering of aerospace electronics
- ▶ Industrial automation fields, such as controllers, drives, servers, robots, etc.

### Main Features

- ▶ Voltage up to 2250V, current up to 5100A, power up to 180kW
- ▶ Supporting master/slave parallel, extended power up to 1.8MW
- ▶ Voltage accuracy 0.05%F.S., current accuracy 0.1%F.S.
- ▶ Voltage and current sampling rate 500kHz, resolution 16 bits
- ▶ LAN port and RS232 interface as standard, GPIB, CAN, RS485 and USB as optional
- ▶ Editable rise and fall slew rate for voltage and current
- ▶ Internal resistance simulation, SEQ function, voltage RAMP function
- ▶ Multiple protections: OCP, OVP, LVP, OTP, OPP
- ▶ Equipped with LCD screen and Chinese/English menu
- ▶ Equipped with high-voltage isolation digital & analog, and monitoring interfaces
- ▶ Power factor 0.99, efficiency up to 93%
- ▶ CC&CV priority function
- ▶ CC, CV and CP mode
- ▶ Standard 19-inch 3U/18kW chassis

### Ultra-wide range, one can be used as several

N38300 series' maximum power is not the result of Max. voltage multiplied by Max. current. Let's take model N38306-300-75 for example. The Max. power is 6kW while Max. voltage 300V and Max. current 75A. Compared with traditional power supply, this feature offers N38300 wider application range, which significantly reduces the purchase cost and space occupation.

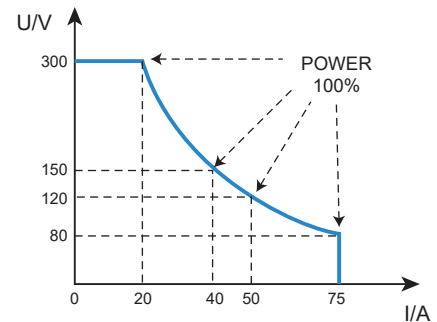

### CC&CV priority function

N38300 has the function of selecting priority of voltage-control loop or current-control loop, which enables N38300 to adopt the optimal test mode for different DUTs, and thus protect the DUT.

As shown in figure one, when the DUT requires reducing voltage overshoot during test, voltage priority mode should be selected to obtain fast and smooth rise voltage.

As shown in figure two, when the DUT requires reducing current overshoot during test, current priority mode should be selected to obtain fast and smooth rise current.

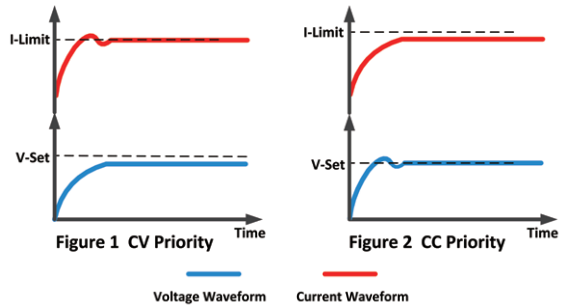

### Internal resistance simulation

N38300 series allows settings of voltage and internal resistance value. According to the corresponding output current, the output voltage is decreased with the set resistance. In this case, the internal resistance of secondary battery, fuel cell and supercapacitor can be simply simulated.

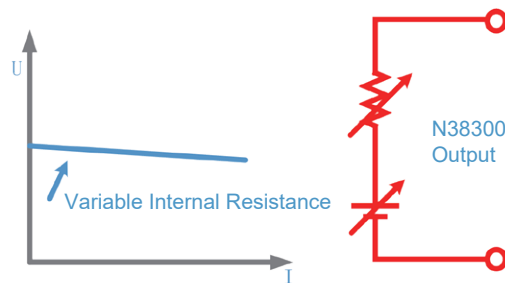

### Master/slave design, convenient for power expansion

N38300 can be used independently or in master/slave parallel operation. It has built-in master/slave mode, and the Max. power can be expanded to 1.8MW. It adopts a unique current sharing design to ensure each module shares the load equally and ensure the consistency of product use.

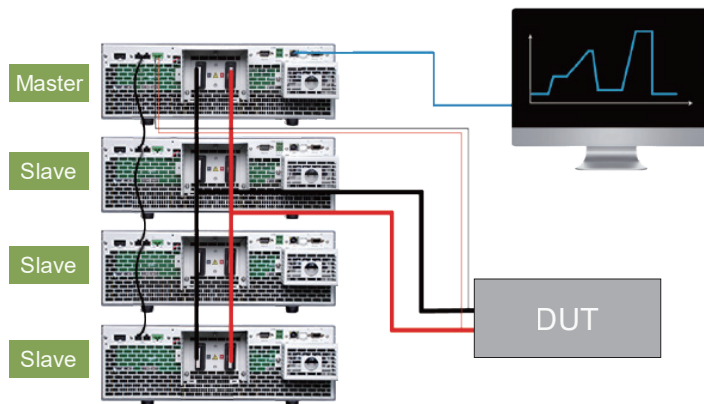

### Quick Selection Table

80V Model	Specification	Size	300V Model	Specification	Size
N38305-80-170	5kW/80V/170A	3U	N38306-300-75	6kW/300V/75A	3U
N38310-80-340	10kW/80V/340A	3U	N38312-300-150	12kW/300V/150A	3U
N38315-80-510	15kW/80V/510A	3U	N38318-300-225	18kW/300V/225A	3U
N38330-80-1020	30kW/80V/1020A	6U	N38336-300-450	36kW/300V/450A	6U
N38345-80-1530	45kW/80V/1530A	16U	N38354-300-675	54kW/300V/675A	16U
N38360-80-2040	60kW/80V/2040A	16U	N38372-300-900	72kW/300V/900A	16U
N38375-80-2550	75kW/80V/2550A	22U	N38390-300-1125	90kW/300V/1125A	22U
N38390-80-3060	90kW/80V/3060A	22U	N383108-300-1350	108kW/300V/1350A	22U
N383105-80-3570	105kW/80V/3570A	27U	N383126-300-1575	126kW/300V/1575A	27U
N383120-80-4080	120kW/80V/4080A	32U	N383144-300-1800	144kW/300V/1800A	32U
N383135-80-4590	135kW/80V/4590A	37U	N383162-300-2025	162kW/300V/2025A	37U
N383150-80-5100	150kW/80V/5100A	37U	N383180-300-2250	180kW/300V/2250A	37U

500V Model	Specification	Size	800V Model	Specification	Size
N38306-500-40	6kW/500V/40A	3U	N38306-800-25	6kW/800V/25A	3U
N38312-500-80	12kW/500V/80A	3U	N38312-800-50	12kW/800V/50A	3U
N38318-500-120	18kW/500V/120A	3U	N38318-800-75	18kW/800V/75A	3U
N38336-500-240	36kW/500V/240A	6U	N38336-800-150	36kW/800V/150A	6U
N38354-500-360	54kW/500V/360A	16U	N38354-800-225	54kW/800V/225A	16U
N38372-500-480	72kW/500V/480A	16U	N38372-800-300	72kW/800V/300A	16U
N38390-500-600	90kW/500V/600A	22U	N38390-800-375	90kW/800V/375A	22U
N383108-500-720	108kW/500V/720A	22U	N383108-800-450	108kW/800V/450A	22U
N383126-500-840	126kW/500V/840A	27U	N383126-800-525	126kW/800V/525A	27U
N383144-500-960	144kW/500V/960A	32U	N383144-800-600	144kW/800V/600A	32U
N383162-500-1080	162kW/500V/1080A	37U	N383162-800-675	162kW/800V/675A	37U
N383180-500-1200	180kW/500V/1200A	37U	N383180-800-750	180kW/800V/750A	37U

1000V Model	Specification	Size	1500V Model	Specification	Size
N38312-1000-40	12kW/1000V/40A	3U	N38312-1500-25	12kW/1500V/25A	3U
N38324-1000-80	24kW/1000V/80A	6U	N38318-1500-40	18kW/1500V/40A	3U
N38336-1000-120	36kW/1000V/120A	16U	N38336-1500-80	36kW/1500V/80A	6U
N38348-1000-160	48kW/1000V/160A	16U	N38354-1500-120	54kW/1500V/120A	16U
N38360-1000-200	60kW/1000V/200A	22U	N38372-1500-160	72kW/1500V/160A	16U
N38372-1000-240	72kW/1000V/240A	22U	N38390-1500-200	90kW/1500V/200A	22U
N38384-1000-280	84kW/1000V/280A	27U	N383108-1500-240	108kW/1500V/240A	22U
N38396-1000-320	96kW/1000V/320A	32U	N383126-1500-280	126kW/1500V/280A	27U
N383108-1000-360	108kW/1000V/360A	37U	N383144-1500-320	144kW/1500V/320A	32U
N383120-1000-400	120kW/1000V/400A	37U	N383162-1500-360	162kW/1500V/360A	37U
/	/	/	N383180-1500-400	180kW/1500V/400A	37U

2250V Model	Specification	Size	2250V Model	Specification	Size
N38318-2250-25	18kW/2250V/25A	3U	N383108-2250-150	108kW/2250V/150A	22U
N38336-2250-50	36kW/2250V/50A	6U	N383126-2250-175	126kW/2250V/175A	27U
N38354-2250-75	54kW/2250V/75A	16U	N383144-2250-200	144kW/2250V/200A	32U
N38372-2250-100	72kW/2250V/100A	16U	N383162-2250-225	162kW/2250V/225A	37U
N38390-2250-125	90kW/2250V/125A	22U	N383180-2250-250	180kW/2250V/250A	37U

\*N38300 series support parallel expansion power, please contact NGI for more specifications.

## Product Dimension

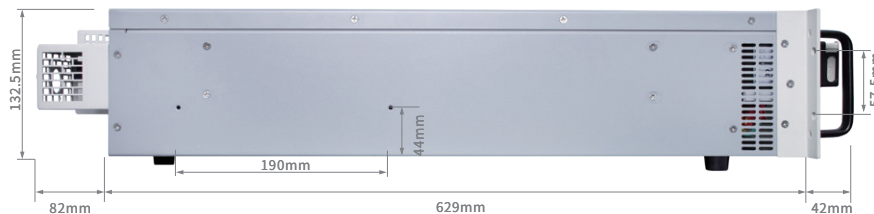
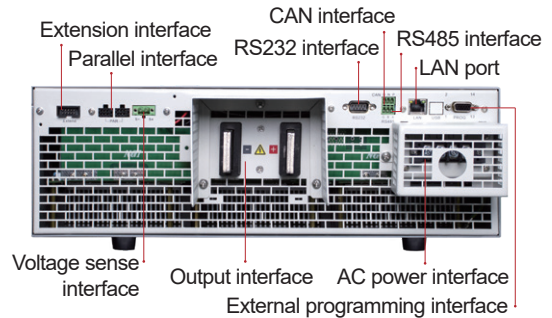
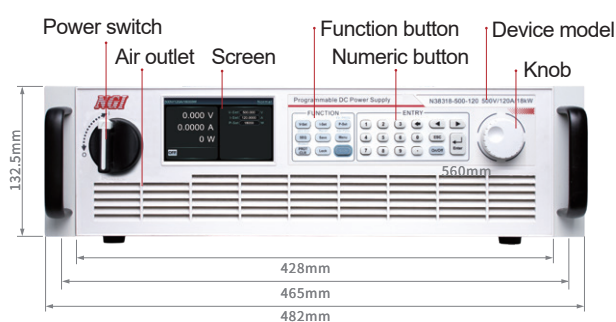

## Technical Data Sheet(1)

Model	N38305-80-170	N38306-300-75	N38306-500-40	N38306-800-25
Voltage	0~80V	0~300V	0~500V	0~800V
Current	0~170A	0~75A	0~40A	0~25A
Power	0~5kW	0~6kW	0~6kW	0~6kW
CV Mode				
Range	0~80V	0~300V	0~500V	0~800V
Setting Resolution	0.1mV	1mV	1mV	1mV
Setting Accuracy (23±5°C)	0.05%+0.05%F.S.			
Voltage Ripple (Vp-p)	≤200mV	≤300mV	≤350mV	≤500mV
Voltage Ripple (rms)	≤25mV	≤40mV	≤35mV	≤100mV
CC Mode				
Range	0~170A	0~75A	0~40A	0~25A
Setting Resolution	1mA	0.1mA	0.1mA	0.1mA
Setting Accuracy (23±5°C)	0.1%+0.1%F.S.			
CP Mode				
Range	0~5kW	0~6kW	0~6kW	0~6kW
Setting Accuracy (23±5°C)	1%F.S.			
Voltage Measurement				
Range	0~80V	0~300V	0~500V	0~800V
Readback Resolution	0.1mV	1mV	1mV	1mV
Readback Accuracy (23±5°C)	0.05%+0.05%F.S.			
Current Measurement				
Range	0~170A	0~75A	0~40A	0~25A
Readback Resolution	1mA	0.1mA	0.1mA	0.1mA
Readback Accuracy (23±5°C)	0.1%+0.1%F.S.			
Line Regulation				
Voltage	≤0.01%F.S.			
Current	≤0.05%F.S.			
Load Regulation				
Voltage	≤0.02%F.S.			
Current	≤0.1%F.S.	≤0.05%F.S.	≤0.05%F.S.	≤0.05%F.S.
Dynamic Characteristics				
Voltage Slew Rate	6V/ms(Max)	10V/ms(Max)	20V/ms(Max)	40V/ms(Max)
Voltage Fall Time(no load) <sup>1</sup>	≤0.5s	≤2.5s	≤2.5s	≤2.5s
Transient Recovery Time	The recovery time of load varying 10%~90% and voltage recovering within 0.75% accuracy range of rated value is within 2ms.			
Others				
Interface	Standard: RS232/LAN, optional: RS485/CAN/GPIB/USB			
Protocol	SCPI/MODBUS-RTU/CAN-Open			
AC Input	Three phase 340VAC~460VAC, frequency 47Hz~63Hz			
Communication Response Time	≤5ms			
Efficiency	92%(Typical)	93%(Typical)		
Power Factor	0.99(Typical)			
Temperature	Operating temperature: 0°C~40°C, storage temperature: -20°C~70°C			
Operating Environment	Altitude <2000m, relative humidity: 5%-90%RH(non-condensing), atmospheric pressure: 80-110kPa			
Net Weight	Approx. 18kg			
Dimension	132.5(H)*482.0(W)with handle*711.0(D)mm, with output shield			

Note 1: The time required for the voltage dropping below 50V when the device output is OFF under full voltage and no-load operation.

Note 2: For other specifications, please contact NGI.

Note 3: All specifications are subject to change without notice.

**Technical Data Sheet(2)**

Model	N38310-80-340	N38312-300-150	N38312-500-80	N38312-800-50
Voltage	0~80V	0~300V	0~500V	0~800V
Current	0~340A	0~150A	0~80A	0~50A
Power	0~10kW	0~12kW	0~12kW	0~12kW
CV Mode				
Range	0~80V	0~300V	0~500V	0~800V
Setting Resolution	0.1mV	1mV	1mV	1mV
Setting Accuracy (23±5°C)	0.05%+0.05%F.S.			
Voltage Ripple (Vp-p)	≤180mV	≤250mV	≤250mV	≤500mV
Voltage Ripple (rms)	≤25mV	≤35mV	≤35mV	≤100mV
CC Mode				
Range	0~340A	0~150A	0~80A	0~50A
Setting Resolution	1mA	1mA	0.1mA	0.1mA
Setting Accuracy (23±5°C)	0.1%+0.1%F.S.			
CP Mode				
Range	0~10kW	0~12kW	0~12kW	0~12kW
Setting Accuracy (23±5°C)	1%F.S.			
Voltage Measurement				
Range	0~80V	0~300V	0~500V	0~800V
Readback Resolution	0.1mV	1mV	1mV	1mV
Readback Accuracy (23±5°C)	0.05%+0.05%F.S.			
Current Measurement				
Range	0~340A	0~150A	0~80A	0~50A
Readback Resolution	1mA	1mA	0.1mA	0.1mA
Readback Accuracy (23±5°C)	0.1%+0.1%F.S.			
Line Regulation				
Voltage	≤0.01%F.S.			
Current	≤0.05%F.S.			
Load Regulation				
Voltage	≤0.02%F.S.			
Current	≤0.1%F.S.	≤0.05%F.S.	≤0.05%F.S.	≤0.05%F.S.
Dynamic Characteristics				
Voltage Slew Rate	6V/ms(Max)	10V/ms(Max)	20V/ms(Max)	40V/ms(Max)
Voltage Fall Time(no load) <sup>1</sup>	≤0.5s	≤2.5s	≤2.5s	≤2.5s
Transient Recovery Time	The recovery time of load varying 10%~90% and voltage recovering within 0.75% accuracy range of rated value is within 2ms.			
Others				
Interface	Standard: RS232/LAN, optional: RS485/CAN/GPIB/USB			
Protocol	SCPI/MODBUS-RTU/CAN-Open			
AC Input	Three phase 340VAC ~ 460VAC, frequency 47Hz ~ 63Hz			
Communication Response Time	≤5ms			
Efficiency	92%(Typical)	93%(Typical)		
Power Factor	0.99(Typical)			
Temperature	Operating temperature: 0°C~40°C, storage temperature: -20°C~70°C			
Operating Environment	Altitude <2000m, relative humidity: 5%-90%RH(non-condensing), atmospheric pressure: 80-110kPa			
Net Weight	Approx. 25kg			
Dimension	132.5(H)*482.0(W)with handle*711.0(D)mm, with output shield			

Note 1: The time required for the voltage dropping below 50V when the device output is OFF under full voltage and no-load operation.

Note 2: For other specifications, please contact NGI.

Note 3: All specifications are subject to change without notice.

### Technical Data Sheet(3)

Model	N38312-1000-40	N38312-1500-25
Voltage	0~1000V	0~1500V
Current	0~40A	0~25A
Power	0~12kW	
CV Mode		
Range	0~1000V	0~1500V
Setting Resolution	10mV	
Setting Accuracy (23±5°C)	0.05%+0.05%F.S.	
Voltage Ripple (Vp-p)	≤850mV	≤1300mV
Voltage Ripple (rms)	≤150mV	≤300mV
CC Mode		
Range	0~40A	0~25A
Setting Resolution	0.1mA	
Setting Accuracy (23±5°C)	0.1%+0.1%F.S.	
CP Mode		
Range	0~12kW	
Setting Accuracy (23±5°C)	1%F.S.	
Voltage Measurement		
Range	0~1000V	0~1500V
Readback Resolution	10mV	
Readback Accuracy (23±5°C)	0.05%+0.05%F.S.	
Current Measurement		
Range	0~40A	0~25A
Readback Resolution	0.1mA	
Readback Accuracy (23±5°C)	0.1%+0.1%F.S.	
Line Regulation		
Voltage	≤0.01%F.S.	
Current	≤0.05%F.S.	
Load Regulation		
Voltage	≤0.02%F.S.	
Current	≤0.05%F.S.	
Dynamic Characteristics		
Voltage Slew Rate	40V/ms(Max)	
Voltage Fall Time(no load) <sup>1</sup>	≤3.5s	≤4s
Transient Recovery Time	The recovery time of load varying 10%~90% and voltage recovering within 0.75% accuracy range of rated value is within 2ms.	
Others		
Interface	Standard: RS232/LAN, optional: RS485/CAN/GPIB/USB	
Protocol	SCPI/MODBUS-RTU/CAN-Open	
AC Input	Three phase 340VAC~460VAC, frequency 47Hz~63Hz	
Communication Response Time	≤5ms	
Efficiency	93%(Typical)	
Power Factor	0.99(Typical)	
Temperature	Operating temperature: 0°C~40°C, storage temperature: -20°C~70°C	
Operating Environment	Altitude <2000m, relative humidity: 5%~90%RH(non-condensing), atmospheric pressure: 80~110kPa	
Net Weight	Approx. 25kg	
Dimension	132.5(H)*482.0(W)with handle*711.0(D)mm, with output shield	

Note 1: The time required for the voltage dropping below 50V when the device output is OFF under full voltage and no-load operation.

Note 2: For other specifications, please contact NGI.

Note 3: All specifications are subject to change without notice.

**Technical Data Sheet(4)**

Model	N38315-80-510	N38318-300-225	N38318-500-120	N38318-800-75
Voltage	0~80V	0~300V	0~500V	0~800V
Current	0~510A	0~225A	0~120A	0~75A
Power	0~15kW	0~18kW	0~18kW	0~18kW
CV Mode				
Range	0~80V	0~300V	0~500V	0~800V
Setting Resolution	0.1mV	1mV	1mV	1mV
Setting Accuracy (23±5°C)	0.05%+0.05%F.S.			
Voltage Ripple (Vp-p)	≤150mV	≤300mV	≤300mV	≤500mV
Voltage Ripple (rms)	≤25mV	≤40mV	≤35mV	≤100mV
CC Mode				
Range	0~510A	0~225A	0~120A	0~75A
Setting Resolution	1mA	1mA	1mA	0.1mA
Setting Accuracy (23±5°C)	0.1%+0.1%F.S.			
CP Mode				
Range	0~15kW	0~18kW	0~18kW	0~18kW
Setting Accuracy (23±5°C)	1%F.S.			
Voltage Measurement				
Range	0~80V	0~300V	0~500V	0~800V
Readback Resolution	0.1mV	1mV	1mV	1mV
Readback Accuracy (23±5°C)	0.05%+0.05%F.S.			
Current Measurement				
Range	0~510A	0~225A	0~120A	0~75A
Readback Resolution	1mA	1mA	1mA	0.1mA
Readback Accuracy (23±5°C)	0.1%+0.1%F.S.			
Line Regulation				
Voltage	≤0.01%F.S.			
Current	≤0.05%F.S.			
Load Regulation				
Voltage	≤0.02%F.S.			
Current	≤0.05%F.S.			
Dynamic Characteristics				
Voltage Slew Rate	6V/ms(Max)	10V/ms(Max)	20V/ms(Max)	40V/ms(Max)
Voltage Fall Time(no load) <sup>1</sup>	≤0.5s	≤2.5s	≤2.5s	≤2.5s
Transient Recovery Time	The recovery time of load varying 10%~90% and voltage recovering within 0.75% accuracy range of rated value is within 2ms.			
Others				
Interface	Standard: RS232/LAN, optional: RS485/CAN/GPIB/USB			
Protocol	SCPI/MODBUS-RTU/CAN-Open			
AC Input	Three phase 340VAC~460VAC, frequency 47Hz~63Hz			
Communication Response Time	≤5ms			
Efficiency	92%(Typical)	93%(Typical)		
Power Factor	0.99(Typical)			
Temperature	Operating temperature: 0°C~40°C, storage temperature: -20°C~70°C			
Operating Environment	Altitude <2000m, relative humidity: 5%~90%RH(non-condensing), atmospheric pressure: 80~110kPa			
Net Weight	Approx. 32kg			
Dimension	132.5(H)*482.0(W)with handle*711.0(D)mm, with output shield			

Note 1: The time required for the voltage dropping below 50V when the device output is OFF under full voltage and no-load operation.

Note 2: For other specifications, please contact NGI.

Note 3: All specifications are subject to change without notice.

## Technical Data Sheet(5)

Model	N38318-1500-40	N38318-2250-25	N38336-300-450
Voltage	0~1500V	0~2250V	0~300V
Current	0~40A	0~25A	0~450A
Power	0~18kW	0~18kW	0~36kW
CV Mode			
Range	0~1500V	0~2250V	0~300V
Setting Resolution	10mV	10mV	1mV
Setting Accuracy (23±5°C)	0.05%+0.05%F.S.		
Voltage Ripple (Vp-p)	≤1300mV	≤2500mV	≤300mV
Voltage Ripple (rms)	≤300mV	≤400mV	≤40mV
CC Mode			
Range	0~40A	0~25A	0~450A
Setting Resolution	0.1mA	0.1mA	1mA
Setting Accuracy (23±5°C)	0.1%+0.1%F.S.		
CP Mode			
Range	0~18kW	0~18kW	0~36kW
Setting Accuracy (23±5°C)	1%F.S.		
Voltage Measurement			
Range	0~1500V	0~2250V	0~300V
Readback Resolution	10mV	10mV	1mV
Readback Accuracy (23±5°C)	0.05%+0.05%F.S.		
Current Measurement			
Range	0~40A	0~25A	0~450A
Readback Resolution	0.1mA	0.1mA	1mA
Readback Accuracy (23±5°C)	0.1%+0.1%F.S.		
Line Regulation			
Voltage	≤0.01%F.S.		
Current	≤0.05%F.S.		
Load Regulation			
Voltage	≤0.02%F.S.		
Current	≤0.05%F.S.		
Dynamic Characteristics			
Voltage Slew Rate	40V/ms(Max)	40V/ms(Max)	10V/ms(Max)
Voltage Fall Time(no load) <sup>1</sup>	≤4s	≤4.5s	≤2s
Transient Recovery Time	The recovery time of load varying 10%~90% and voltage recovering within 0.75% accuracy range of rated value is within 2ms.		
Others			
Interface	Standard: RS232/LAN, optional: RS485/CAN/GPIB/USB		
Protocol	SCPI/MODBUS-RTU/CAN-Open		
AC Input	Three phase 340VAC~460VAC, frequency 47Hz~63Hz		
Communication Response Time	≤5ms		
Efficiency	93%(Typical)		
Power Factor	0.99(Typical)		
Temperature	Operating temperature: 0°C~40°C, storage temperature: -20°C~70°C		
Operating Environment	Altitude <2000m, relative humidity: 5%~90%RH(non-condensing), atmospheric pressure: 80~110kPa		
Net Weight	Approx. 32kg		Approx. 64kg
Dimension	132.5(H)*482.0(W)with handle*711.0(D)mm, with output shield		265.0(H)*482.0(W)with handle*753.0(D)mm with output shield

Note 1: The time required for the voltage dropping below 50V when the device output is OFF under full voltage and no-load operation.

Note 2: For other specifications, please contact NGI.

Note 3: All specifications are subject to change without notice.